

NOTES:

- 1,000 lbs. WORKING LOAD IN ANY DIRECTION.
- ASSEMBLY SHOWN IS 12", 15", 18" HIGH MODELS FOR WELDING TO EMBED PLATE CAST IN STANDARD HOLLOW CORE SLAB.
- ASSEMBLY SHOWN WITH CONVENTIONAL SINGLE PLY ROOFING (BY OTHERS).

IMPORTANT:

- FALL ARREST SAFETY ANCHORS ARE DESIGNED TO A TYPICAL MAXIMUM FALL ARREST FORCE OF 1,800 lbs. (8.0 KN) WHEN WEARING A BODY HARNESS, WITH A FACTOR OF SAFETY OF 2 WITHOUT ANY PERMANENT DEFORMATION, AND TO 5,000 lbs. (22.2 KN) AGAINST FRACTURE OR DETACHMENT.
- IT IS THE RESPONSIBILITY OF THE STRUCTURAL ENGINEER FOR THE OVERALL PROJECT TO ENSURE THAT THE STRUCTURE ON WHICH THE SAFETY EQUIPMENT BY PRO-BEL IS INSTALLED, IS REINFORCED TO WITHSTAND THE LOADS INDICATED ON THIS DRAWING.

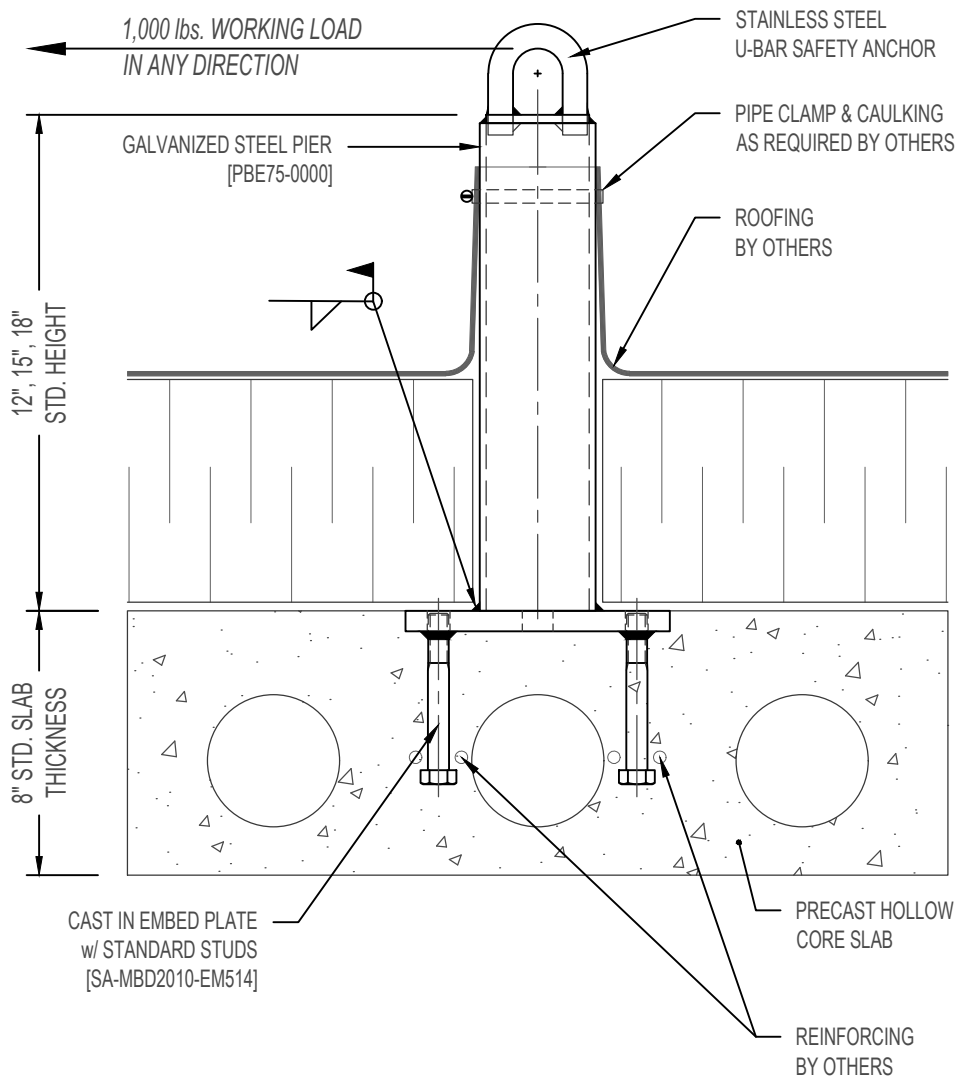

PBE94-00B4: WELD TO EMBED PLATE [STANDARD S.S. STUD] ROOF ANCHOR