



Pro-Bel Group Ltd.
765 Westney Road South
Ajax, Ontario, Canada L1S 6W1

Toll Free: (800) 461-0575
Tel: (905)-427-0616
Fax: (905)-427-2545
Email: info@pro-belgroup.com



NOTES:

1. SYSTEM SHOWN BELOW IS FOR 1,000 lbs. WORKING LOAD.
2. ASSEMBLY SHOWN IS TOP ROTATING DAVIT ARM TYPE A501.
3. MODEL SHOWN IS FOR A GROUND RIGGED APPLICATION ONLY.

IMPORTANT:

1. DAVITS ARE DESIGNED TO A TYPICAL SUSPENSION LOAD OF 1,000 lbs. (4.5 KN), WITH A FACTOR OF SAFETY OF 4 AGAINST FRACTURE OR DETACHMENT.
2. IT IS THE RESPONSIBILITY OF THE STRUCTURAL ENGINEER FOR THE OVERALL PROJECT TO ENSURE THAT THE STRUCTURE ON WHICH THE SAFETY EQUIPMENT BY PRO-BEL IS INSTALLED, IS REINFORCED TO WITHSTAND THE LOADS INDICATED ON THIS DRAWING.

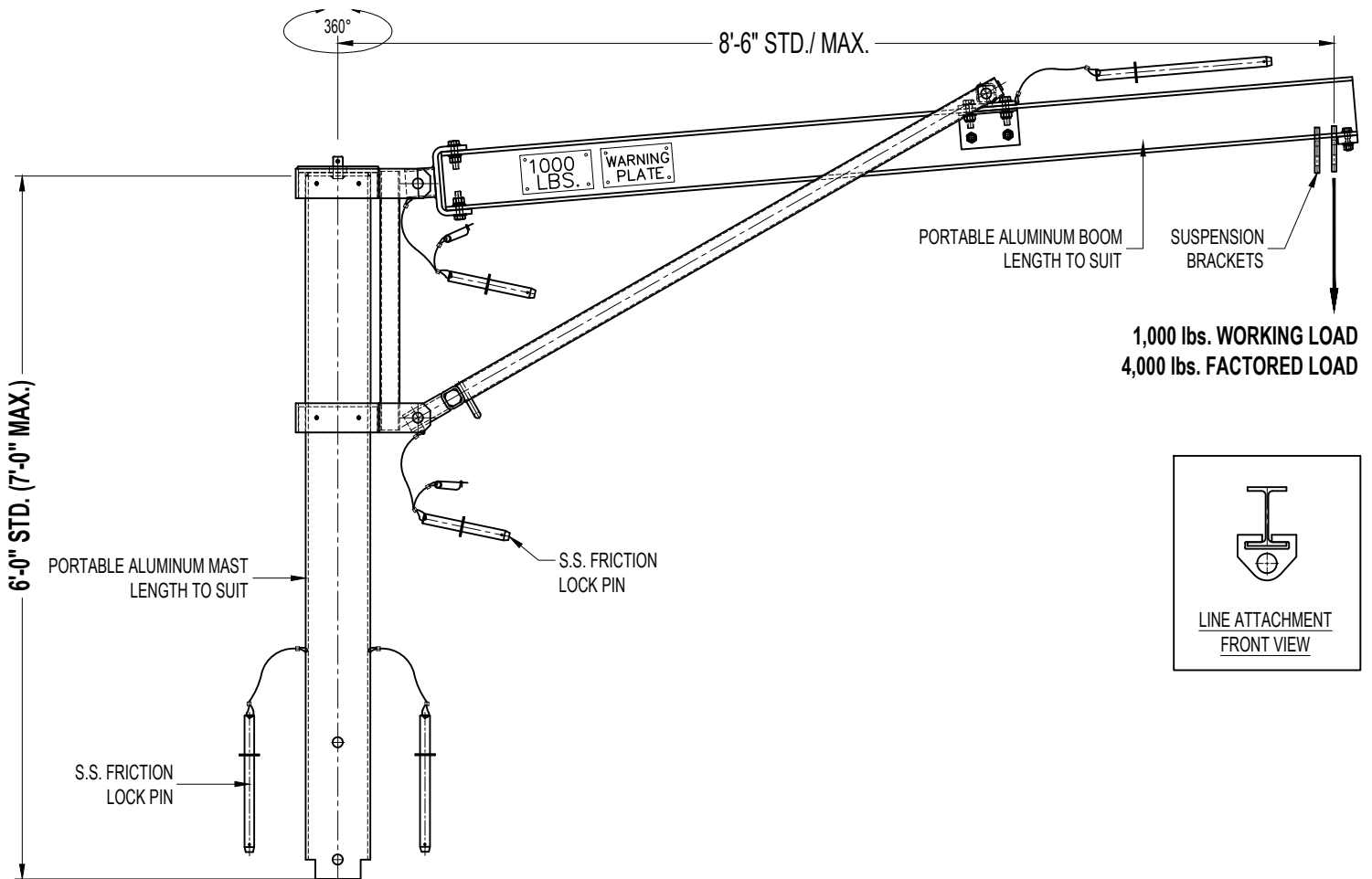

DAVIT ARM ASSEMBLY - A501